

## TTC 2310 – Powerful Safety Electronic Control Unit

### General description

The robust and powerful TTC 2310 mid-sized electronic control solution is equipped with Infineon's TriCore™ Aurix™ TC 377 CPU to fulfill the demanding performance requirements of automotive safety applications.

Protected by a compact and robust housing, the device was especially developed for vehicles used in a rugged operating environment and at extreme operating temperatures. Due to the ISO 26262 ASIL C automotive safety certification, the device is also used in road vehicles.

### Specifications

Parameter		Unit
ECU dimensions	170.6 x 232.0 x 42.0	mm
Dimensions for minimum connector release clearance	70.0 x 182.0 x 50.0	mm
Weight	1215	g
Connector	2 x 48	pins
Operating temperature	-40 to +85	°C
Operating altitude	0 to 4000	m
Supply voltage	8 to 32	V
Maximum supply current at 12 / 24V without load	200 / 130	mA
Maximum standby current	<1	mA
Maximum total load current	45	A

### Standards

Functional safety	IEC 61508 SIL2 EN ISO 13849 PL d ISO 25119 AgPL d SRL2	ISO 26262 ASIL C ISO 19014 MPL d
CE-Mark	2014/30/EU 2006/42/EC	
E-Mark	ECE-R10 Rev.6	
FCC-Mark	47 CFR Part 15B, Class A	
EMC	EN 13766 ISO 14982 CISPR 25	IEC 61000-4-2/-3/-4/-5/-6/-8 IEC 61000-6-4
ESD	ISO 10605	
Electrical	ISO 16750-2 ISO 7637-2,-3	
Ingress protection	EN 60529 IP65 and IP67 ISO 20653 IP6k9k	
Climatic	ISO 16750-4	
Mechanical	ISO 16750-3	
ISOBUS	ISO 11783	

### Software

- C Programming Environment with real-time operating system
- CODESYS®\* Safety SIL 2 including support for CANopen® Safety Master

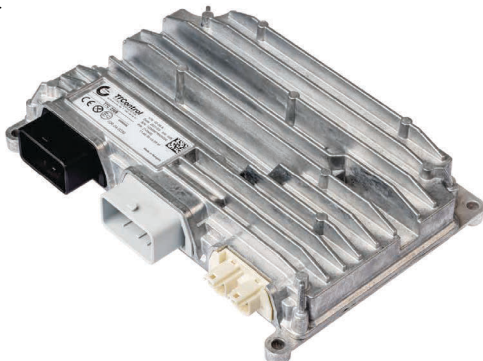

### Features

#### CPU core

- 32-Bit Infineon TriCore™ Aurix™ TC377
- 3 cores (2 lockstep cores) running at 300 MHz and memory protection for safety-relevant applications
- Floating-Point Unit and Hardware Security Module
- 992 KB int. SRAM, 6 MB int. Flash
- 16 MB ext. Flash, 8 kB FRAM, 256 KB int. EEPROM emulation

#### Interfaces

- 4 x CAN FD 50 kbit/s up to 2 Mbit/s (1 x CAN FD with wake-up capability and 1 x CAN FD ISOBUS)
- 1 x CAN bus termination configurable via connector pins
- 4 x SENT with SPC support, 1 x LIN

#### Outputs

- 10 x PWM OUT up to 1 kHz or digital OUT, up to 4 A (2 x up to 8 A), high side, with current measurement, alternative use as digital timer IN (0.1 Hz - 20 kHz) configurable pull-up in groups of 2 or analog IN 12 bit, 0 - 32 V or LED control OUT
- 18 x digital OUT up to 4 A, high side, with current sense alternative use 4 x as voltage OUT 0 - 10 V or 10 x as PVG OUT, 10 - 90% of BAT+ or 8 x as digital timer IN (0.1 Hz - 20 kHz) or LED control OUT or analog IN 12 bit, 0 - 32 V
- 8 x PWM OUT up to 4 kHz, up to 4 A, low side, with current measurement (4 x featuring timer feedback) alternative use as analog IN 12 bit, 0 - 5 V, 0 - 32 V or 4 x as digital timer IN (0.1 Hz - 20 kHz)
- 1 x emergency stop OUT\*, alternative use as analog IN 12 bit, 0 - 32 V
- Option to configure up to 4 x H-bridges for motor control\*
- 3 x status LED

#### Inputs

- 8 x analog IN 12 bit, 0 - 5 V, 0 - 25 mA, 0 - 100 kOhm, LED control
- 4 x analog IN 12 bit, 0 - 5 V, 0 - 32 V
- 8 x digital timer IN (0.1 Hz - 20 kHz), encoder support, configurable pull-up/down, support for 7/14 mA current loop speed sensors alternative use as analog IN 12 bit, 0 - 32 V, 0 - 25 mA
- 4 x digital timer IN (0.1 Hz - 20 kHz), encoder support, configurable pull-up, alternative use as analog IN 12 bit, 0 - 32 V or SENT interface
- 2 x emergency stop IN\*, alternative use as analog IN 12 bit, 0 - 32 V
- Terminal 15 and Wake-Up pin

#### Sensor supply

- 2 x sensor supply, 5 V, max. 500 mA
- 1 x sensor supply, 5 - 12 V, max. 2.5 W, configurable by SW in 0.5 V steps

All inputs and outputs supporting analog IN can also be used as digital Input.

All I/Os and interfaces are protected against short circuit to GND and BAT+, and can be configured by software.

Board temperature, sensor supply, and supply voltage are monitored by software.

Two independent shut-off groups for PWM output stages. Details to the standards can be found in the system manual.

\* upcoming feature

## Block diagram

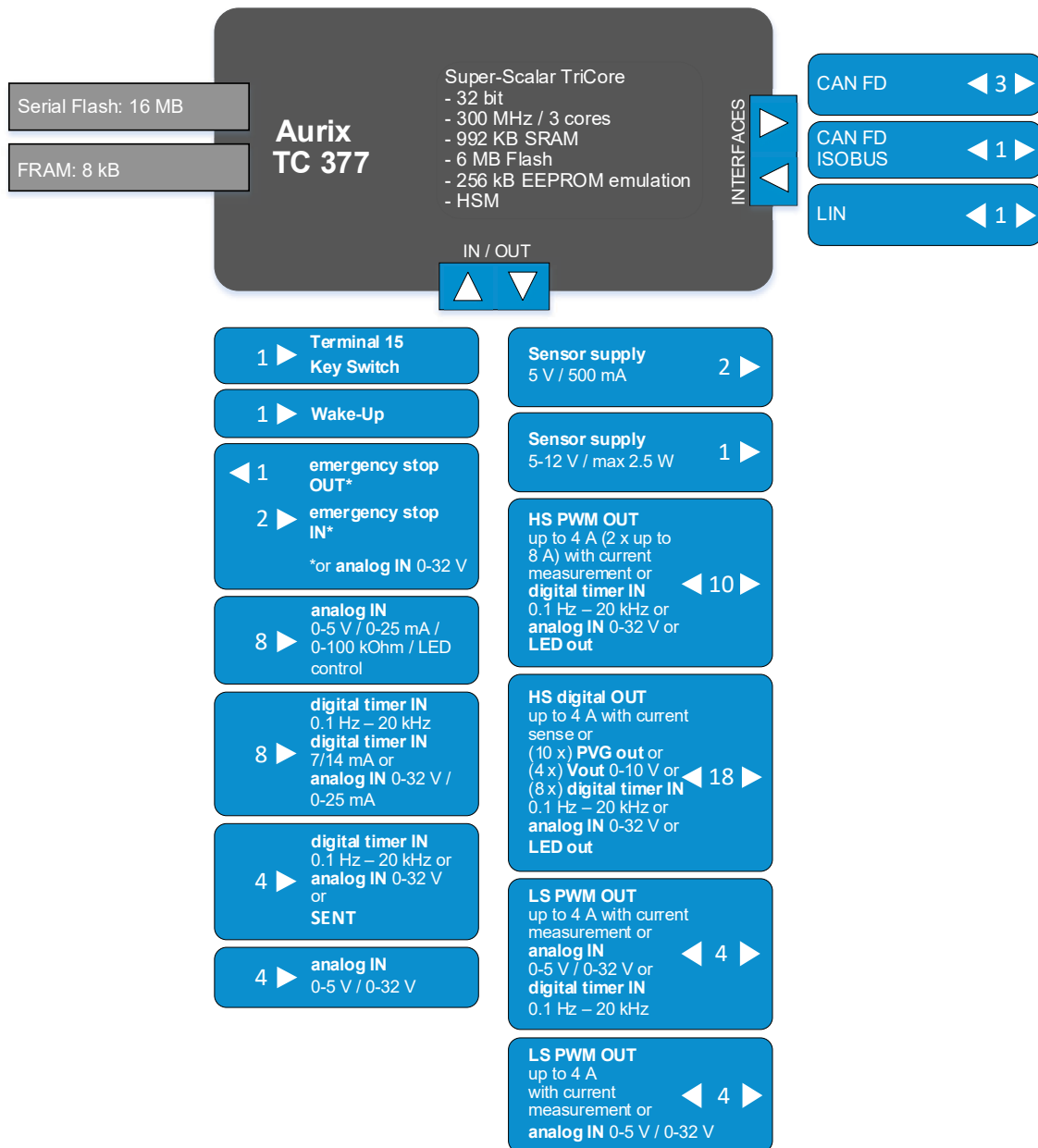

## Housing and connector

Aluminum die-cast housing

2 x 48-pin connectors

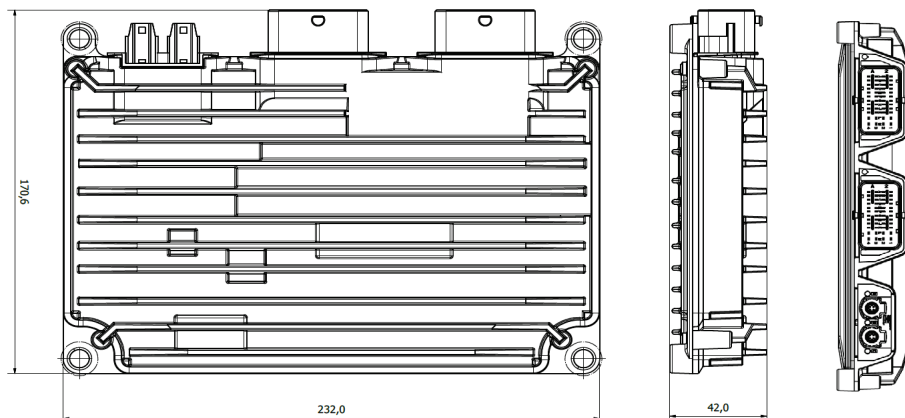

For further information, including price and availability, please contact [products@tttech-auto.com](mailto:products@tttech-auto.com).

Subject to changes and corrections. TTC 2310 is a product name of TTCControl GmbH. CODESYS is a trademark of 3S Smart Software Solutions GmbH. CANopen is a trademark of CAN in Automation (CiA). All other trademarks are the property of their respective holders. To the extent possible under applicable law TTTech Auto hereby disclaims any and all liability for the content and use of this product flyer.