

High-Performance Safety Controller – HY-TTC 540

General Description

HY-TTC 540 is a high-end electronic control solution for the automotive industry, suitable for a wide range of applications. The core of the controller is the very powerful TMS570 CPU designed for use in demanding, safety-critical and complex automotive and transportation scenarios. The HY-TTC 540 fulfills safety requirements up to ASIL C (ISO 26262) / SIL 2 (IEC 61508) / PL d (ISO 13849).

The HY-TTC 540 is part of a complete and compatible product family and is protected by a rugged automotive housing.

Specifications

Parameter		Unit
ECU dimensions	231.3 x 204.9 x 38.8	mm
Dimensions for minimum connector release clearance	315.3 x 204.9 x 38.8	mm
Weight	1,200	g
Connector	154	pins
Operating temperature	-40 to +85	°C
Operating altitude	0 to 4,000	m
Supply voltage	8 to 32	V
Peak supply voltage	45	V _{max}
Supply current at 12/24V without load	400/200	mA _{max}
Standby current	<1	mA _{max}
Total load current	50	A _{max}
Standards		
Functional safety	IEC 61508 SIL 2 EN ISO 13849 PL d ISO 26262 ASIL C (envisaged)	
CE-Mark	2014/30/EU 2006/42/EC	
E-Mark	ECE-R10 Rev.4	
EMC	EN 13309 ISO 14982 CISPR 25	
ESD	ISO 10605	
Electrical	ISO 16750-2 ISO 7637-2,-3	
Ingress protection	EN 60529 IP67 ISO 20653 IP6k9k	
Climatic	ISO 16750-4	
Mechanical	ISO 16750-3	

Software Options

- C programming environment (incl. BSP and driver library)
- MATLAB Simulink I/O block library
- CODESYS® Safety SIL 2 and CODESYS® V3 including support for CANopen® Safety Master



Features

CPU core

- 32-Bit TI TMS570, ARM cortex-R4F based
- Dual-core lockstep CPU and memory protection for safety-relevant applications
- 180 MHz, 298 DMIPS, Floating-Point Unit
- 3 MB int. Flash, 256 kB int. RAM
- 2 MB ext. RAM, 64 kB ext. EEPROM
- Safety Companion CPU

Interfaces

- 4 x CAN 50 kbit/s up to 1 Mbit/s
- 4 x CAN bus termination, configurable via connector pins

Outputs

- 28 x PWM OUT or digital OUT, up to 4 A, high side, with high side current measurement
- 8 x digital OUT up to 4 A, high side, overload and open load detection, current sense alternative use as LED control OUT or analog IN 0 – 32 V, with configurable pull-up/down
- 8 x digital OUT up to 4 A, low side, current sense, overload and open load detection, alternative use as analog IN, 0 – 32 V
- Wiring option to use up to 8 of the digital OUT, high side and 8 digital OUT, low side, as full H-bridge for motor control

Inputs

- 8 x analog IN 12 bit, 0 - 5 V, 0 - 25 mA, 0 - 100 kOhm
- 8 x analog IN 12 bit, 0 - 5 V, 0 - 10 V, 0 - 25 mA
- 8 x analog IN 12 bit, 0 - 5 V, 0 - 32 V, 0 - 25 mA
- 6 x digital timer IN (0.1 Hz - 20 kHz), encoder supporting digital voltage sensors with configurable pull-up/down, digital (7/14 mA) current loop speed-sensor alternative use as analog IN 12 bit, 0 – 32 V
- 6 x digital timer IN (0.1 Hz - 20 kHz), encoder supporting digital voltage sensors with configurable pull-up/down, alternative use as analog IN 12 bit, 0 – 32 V
- 8 x digital timer IN (0.1 Hz - 10 kHz) with pull-up
- 8 x analog IN 12 bit, 0 – 32 V
- K15 and wake up

Sensor Supply

- 2 x sensor supply, 5 V, max. 500 mA
- 1 x sensor supply, 5 – 10 V, max. 2.5 W, configurable by SW in 1 V steps

All I/Os and interfaces are protected against short circuit to GND and BAT+ and can be configured by software.

Board temperature, sensor supply and supply voltage are monitored by the software.

Inputs and outputs can also be used as digital input.

Two independent shut-off groups for PWM output stages.

Details about the standards can be found in the system manual.

Block Diagram

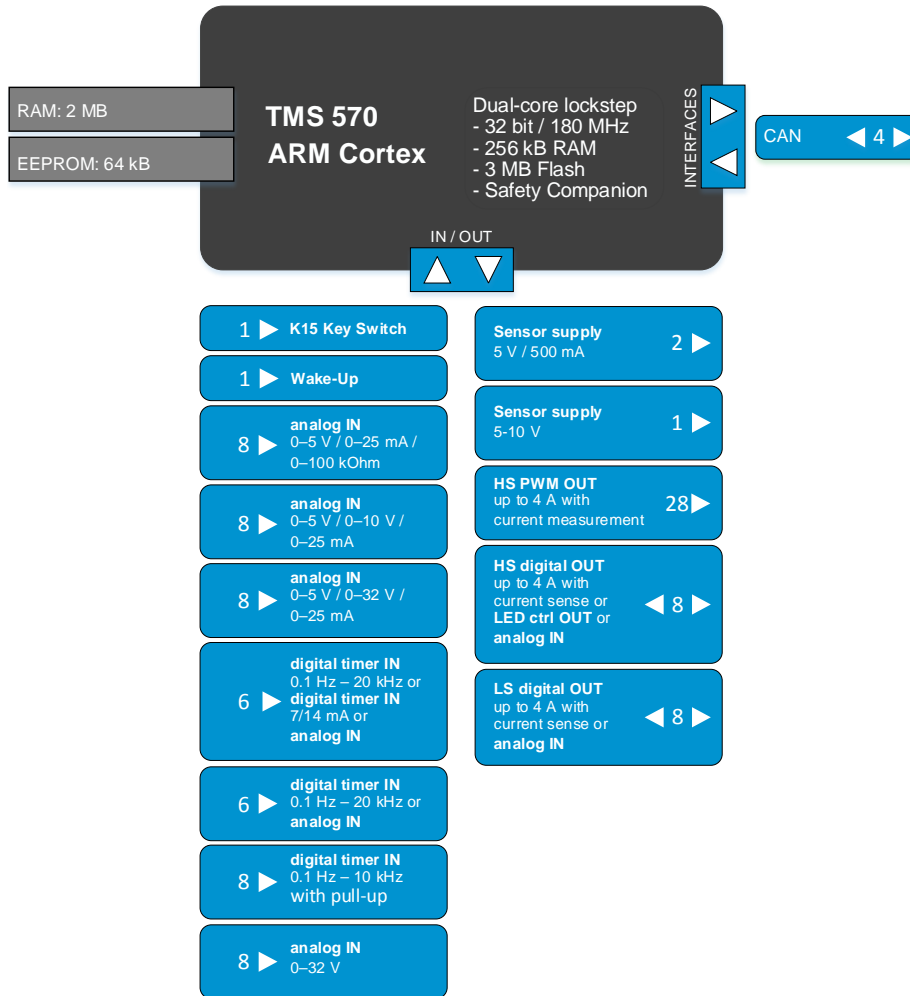

Housing and Connector

Aluminum die-cast housing

154-pin connector

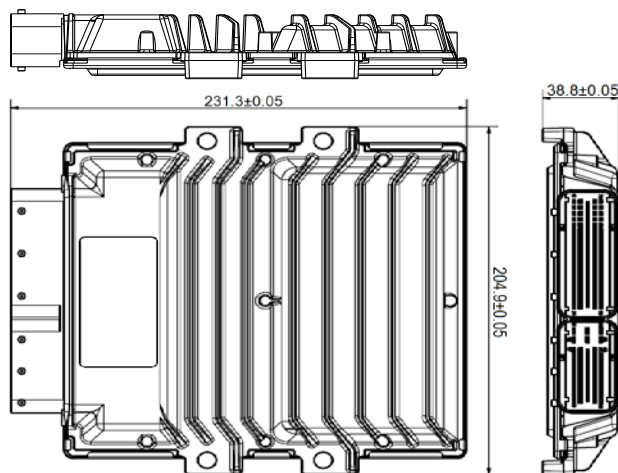

For further information, including prices and availability, please contact products@tttech-auto.com.